



RETRÒ

**GARANTIE
2 JAHRE**

MATERIAL:

Sammel- und Heizröhre aus Messing

WANDBEFESTIGUNGEN:

- Befestigungen sind im Produkt, integriert inklusive Schrauben und Dübel
- Entlüftungsventil
- Montageanleitung

VERPACKUNG:

Die Heizkörper sind mit einer recyclebarer Schrumpffolie geschützt und in einer recyclebarer Kartonschachtel verpackt. Montage und Bedienungsanleitung beiliegend.

FINISH:

Verchromt, antikes Bronze, antikes Gold.

PRODUKT ZERTIFIKATE



Maximaler Betriebsdruck: 5 bar

Maximale Betriebstemperatur: 110° C

Funktion: Warmwasser-Betrieb

Anschlüsse: 2 x G 1/2" I.G. – Entlüftungsventil im Handtuchwärmer integriert

KOMFORTZUBEHÖR

 <p>WINKELVENTIL UND RÜCKLAUFVERSCHRAUBUNG MANUELL ANTIKES GOLD</p> <p>Kupfer Ø 12/14/15/16 Art. Nr. 5991990311132</p> <p>Mehrschichtverbundrohr Ø 16 x2 Art. Nr. 5991990311133</p>	 <p>SET- WINKELVENTIL UND RÜCKLAUFVERSCHRAUBUNG MANUELL VERCHROMT</p> <p>Kupfer Ø 12/14/15/16 Art. Nr. 5991990311134</p> <p>Mehrschichtverbundrohr Ø 16 x2 Art. Nr. 5991990311135</p>	 <p>WINKELVENTIL UND RÜCKLAUFVERSCHRAUBUNG MANUELL ANTIKES BRONZE</p> <p>Kupfer Ø 12/14/15/16 Art. Nr. 5991990311130</p> <p>Mehrschichtverbundrohr Ø 16 x2 Art. Nr. 5991990311131</p>
---	---	---

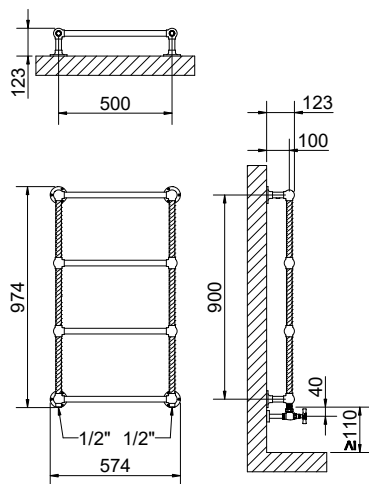
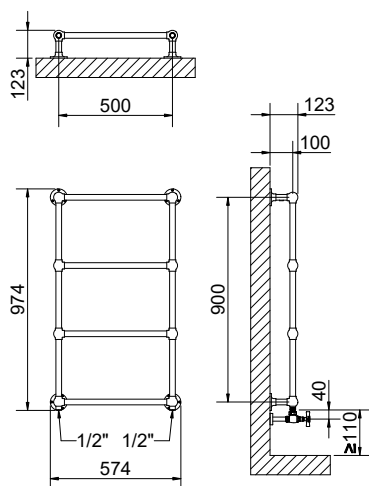
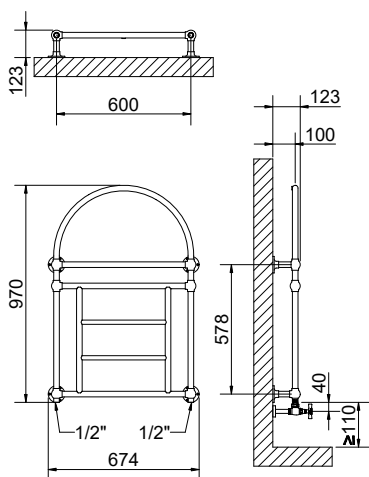
VERCHROMT
AUSFÜHRUNGANTIKES GOLD
AUSFÜHRUNGVERCHROMT
AUSFÜHRUNG

RETRÒ I

Art. Nr.	Bau- höhe [mm]	Bau- länge [mm]	Nabenab- stand l [mm]	Farbe	Norm- Wärmeleistung nach EN 442		
					$\Delta t = 50^{\circ}\text{C}$	$\Delta t = 42,5^{\circ}\text{C}$	$\Delta t = 30^{\circ}\text{C}$
3551330150001				ANTIKES GOLD			
3551330150002	975	575	500	VERCHROMT	178	141	86
3551330150003				ANTIKES BRONZE			

RETRÒ II

Art. Nr.	Bau- höhe [mm]	Bau- länge [mm]	Nabenab- stand l [mm]	Farbe	Norm- Wärmeleistung nach EN 442		
					$\Delta t = 50^{\circ}\text{C}$	$\Delta t = 42,5^{\circ}\text{C}$	$\Delta t = 30^{\circ}\text{C}$
3551330150011				ANTIKES GOLD			
3551330150012	975	575	500	VERCHROMT	178	141	86
3551330150013				ANTIKES BRONZE			

RETRÒ III

Art. Nr.	Bau- höhe [mm]	Bau- länge [mm]	Nabenab- stand l [mm]	Farbe	Norm- Wärmeleistung nach EN 442		
					$\Delta t = 50^{\circ}\text{C}$	$\Delta t = 42,5^{\circ}\text{C}$	$\Delta t = 30^{\circ}\text{C}$
3551330150021				ANTIKES GOLD			
3551330150022	970	675	600	VERCHROMT	242	192	116
3551330150023				ANTIKES BRONZE			

KOMFORTZUBEHÖR

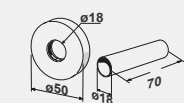
ROHRABDECKUNGSSETS
ANTIKES GOLD

Art. Nr. 5103000000108

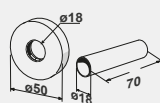
ROHRABDECKUNGSSETS
VERCHROMT

Art. Nr. 5103000000044

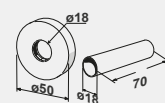
ROHRABDECKUNGSSETS
ANTIKES BRONZE

Art. Nr. 5103000000109